

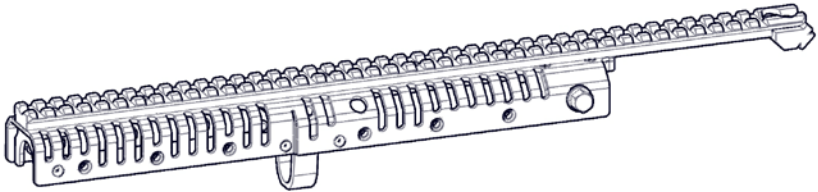

VLTOR WEAPON SYSTEMS

CAS-14 M1A Handguard



**READ
THIS!**

Improper installation can result in damage. Do not attempt installation if you are not familiar with the firearm, tools and techniques mentioned. You are responsible for any damage or injury resulting from the improper use or installation of this product.

WARNING:
Make sure firearm is unloaded of any live cartridges.

1. With rifle field stripped and stock removed, drive out roll pin from stripper clip guide and install Rear Mounting Block, from left to right. Secure using roll pin, making sure it sits flush.

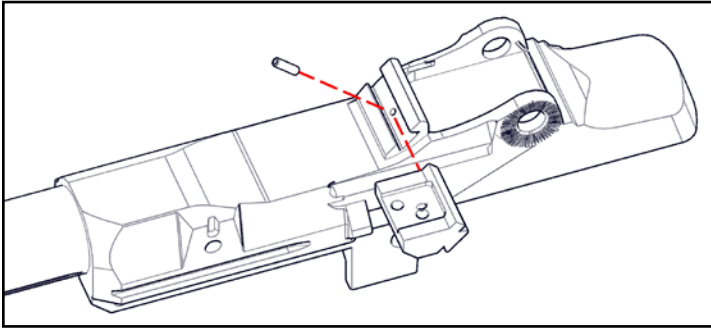

2. Install Barrel Clamp, orient as shown.

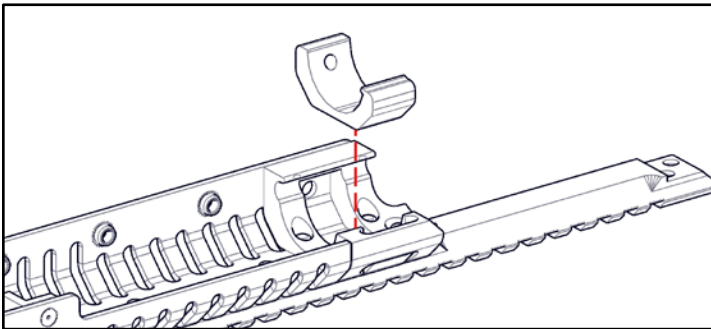

3. **Carefully** seat barreled receiver onto handguard. This is best done by rocking it into position as shown.

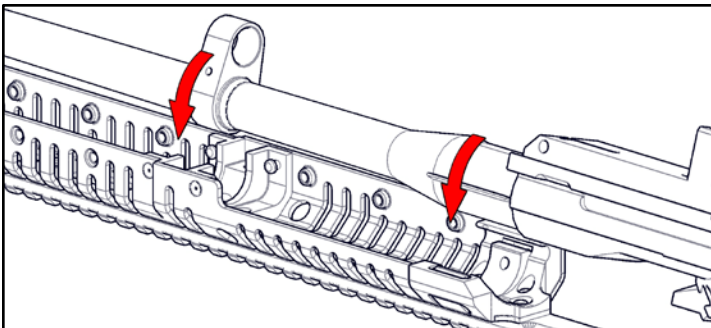

4. Install mounting hardware, starting with Modified Screw on Rear Mounting Block. Thread Modified Screw and Rear Block Screw into the Nut Plate. Note that you'll want to leave the Flanged Bolt & Clamp Screws hand tight in order to properly align top rail.

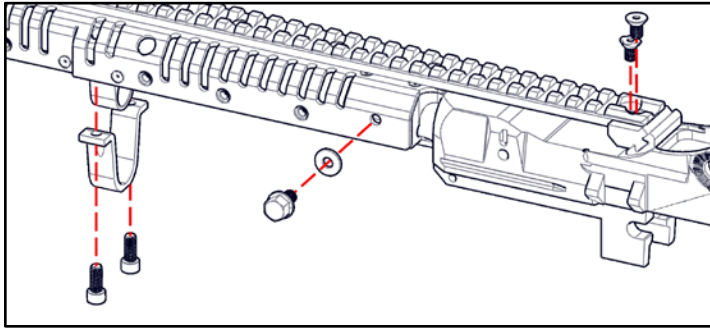

5. Align Upper Handguard to sights. Once straight, tighten Flanged Bolt & Clamp Screws. For best results, tighten Clamp Screws in alternating pattern.

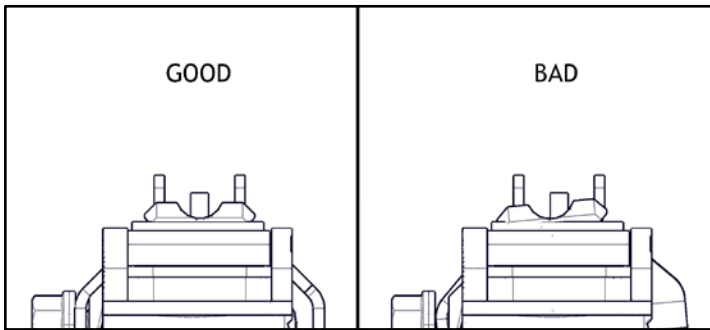

Optional Accessories - The CAS-14 Handguard will accept optional accessory rails as well as QD Sling Swivels.

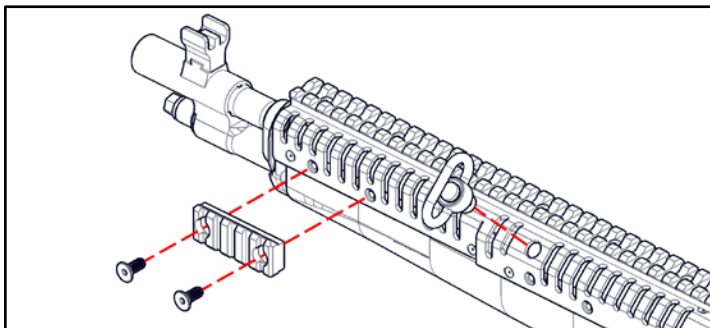

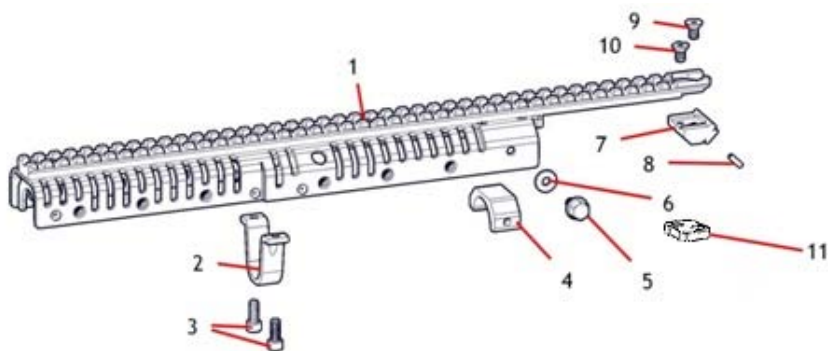

- 1 - CAS-14 Upper Handguard
- 2 - Op-Rod Guide Clamp
- 3 - Clamp Bolts
- 4 - Barrel Clamp
- 5 - Flanged Bolt
- 6 - Washer
- 7 - Rear Mounting Block
- 8 - Roll Pin
- 9 - Rear Block Screw
- 10 - Rear Block Screw (Modified)
- 11 - Nut Plate

Vltor Weapon Systems

www.vltor.com - support@vltor.com

(520) 408-1944 Fax (520) 293-8807

Thank you for choosing Vltor!

Copyright 2007 - Vltor Weapon Systems, all rights are reserved.

VISIT OUR ONLINE STORE NOW

WWW.VLTORSTORE.COM

VWS-M015 Rev A