

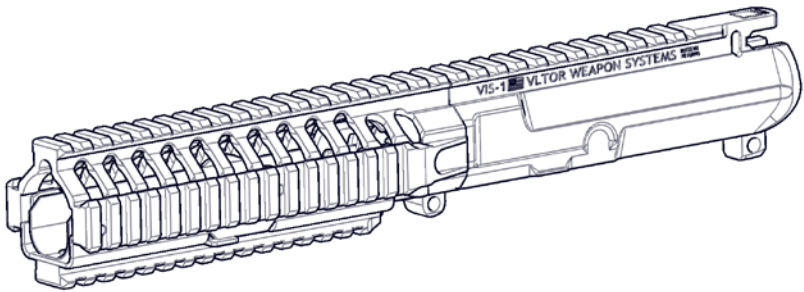

VLTOR WEAPON SYSTEMS

VIS Receiver



**READ
THIS!**

Improper installation can result in damage. Do not attempt installation if you are not familiar with the firearm, tools and techniques mentioned. You are responsible for any damage or injury resulting from the improper use or installation of this product.

1. Install Barrel Nut onto barrel and secure VIS receiver on action block.

Protip: We recommend the DPMS "Panther Claw" action block for all VLTOR receivers.

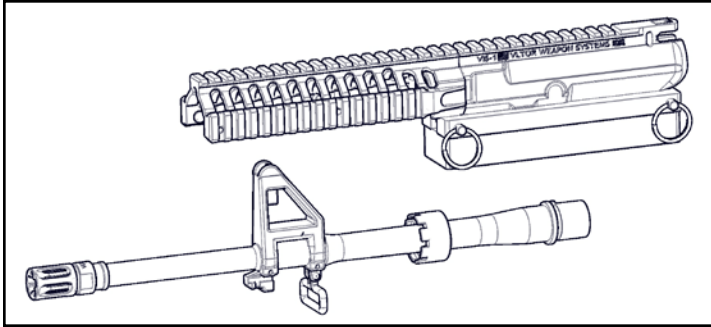

2. Lubricate barrel extension and gently install into receiver, insuring that the indexing pin of barrel extension is aligned with notch in VIS receiver.

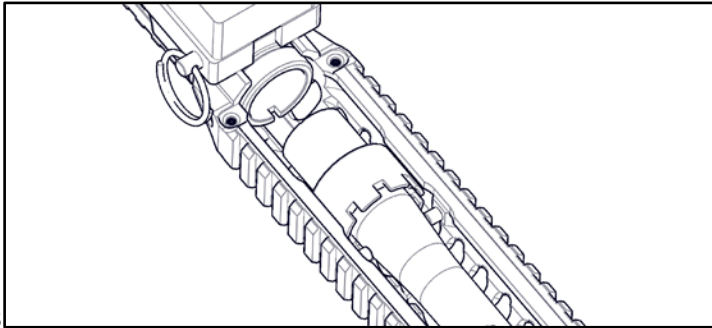

3. Apply anti-seize to threads of receiver and install Barrel Nut by hand. Once threaded, use included Barrel Nut Wrench to tighten Barrel Nut to 40 Foot Pounds.

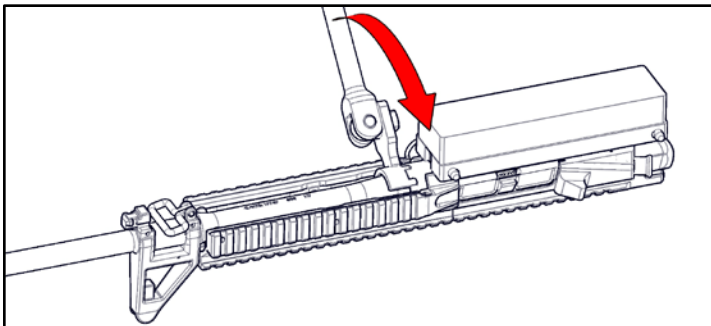

4. Use two included bolts to secure M203 Mounting Bracket to Receiver.

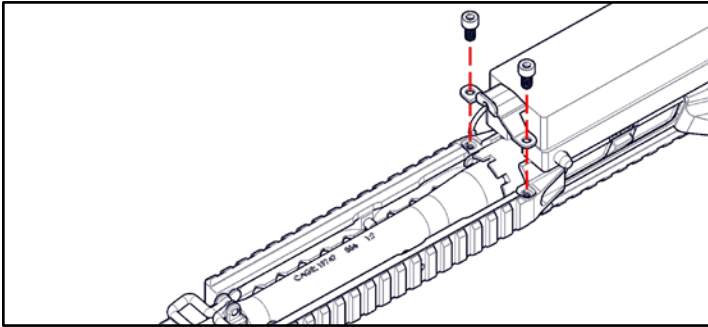

5. Install lower handguard, front first, into VIS receiver.

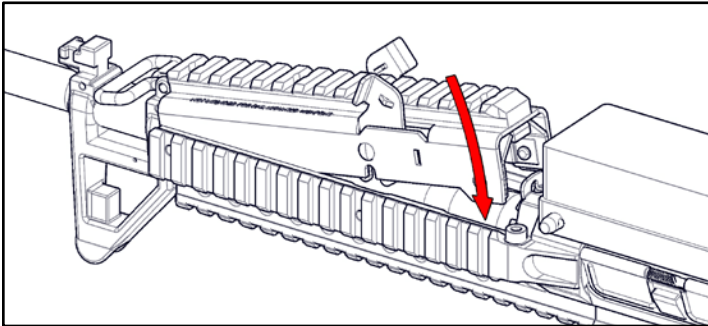

6. Once fully seated, use moderate thumb pressure to close locking tabs and secure lower handguard.

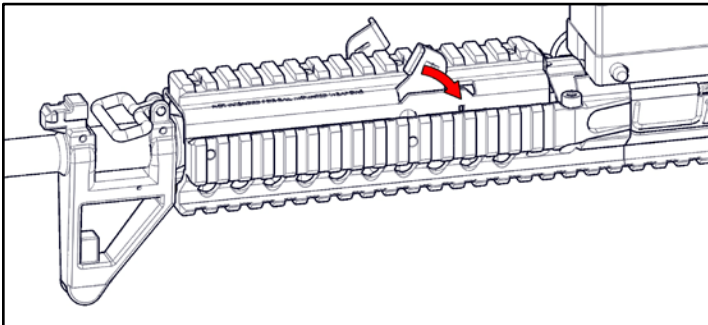

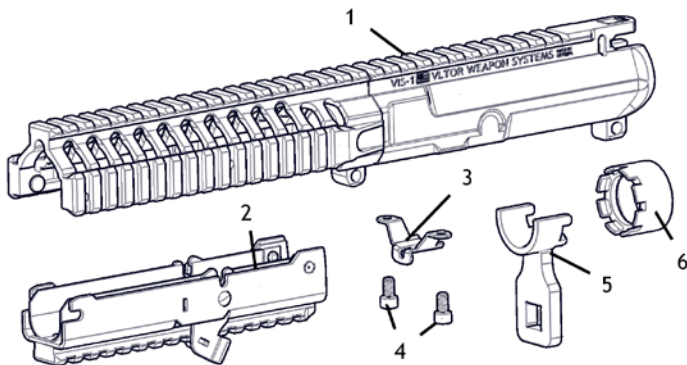

- 1 - VIS Receiver
- 2 - Lower Handguard
- 3 - M203 Mounting Bracket
- 4 - Bracket Bolts
- 5 - Barrel Nut Wrench
- 6 - Barrel Nut

Vltor Weapon Systems

www.vltor.com - support@vltor.com

(520) 408-1944 Fax (520) 293-8807

Thank you for choosing Vltor!

Copyright 2007 - Vltor Weapon Systems, all rights are reserved.

VISIT OUR ONLINE STORE NOW

WWW.VLTORSTORE.COM