

Installation Instructions for the Vltor CASV SCAR handguard.



Congratulations on the purchase of your Vltor CASV SCAR handguard.

Before attempting installation, please read the warnings and notes first.

WARNING: The installation of any Vltor firearm component should be performed by a qualified gunsmith or qualified United States military small-arms technician.

A note to qualified installers: Refer to the current United States Military Technical Manuals or FNH Factory Technical Manuals for the proper understanding of the weapon that this Vltor product attaches to. All parts, which interface with this CASV SCAR handguard, should be new and certified by FNH and/or the United States Military. All mating parts must be of MilSpec quality and dimensions.

Each CASV SCAR kit contains the following components:

- Qty.2 Side Plates
- Qty.1 Lower Handguard Assembly
- Qty.2 10-32 Button Head Socket Cap Screw (BHCS)
- Qty.4 M4 Button Head Socket Cap Screw (BHCS)
- Qty.6 6-32 Flat Head Socket Cap Screw (FHCS)
- Qty.2 10-32 Flat Head Torx Screw (FHTS)
- Qty.2 4-inch Accessory Rails*
- Qty.2 2-inch Accessory Rails*
- Qty.11 10-32 x ½ Flathead Socket Cap Screws * (FHCS)
- Qty.2 Hex Wrenches for Mounting Clamp and Accessory Rail Installation
- Qty.1 Torx Key for Handguard Installation

*Note: Not included in SCAR CASV-X kit.

Assembly Instructions

1. ***Make sure the weapon is unloaded and that the chamber is cleared.***
2. Remove the lower handguard/accessory rail. Note that heat may need to be applied in order to break the thread-locker applied at the factory. Use care and caution when applying heat.

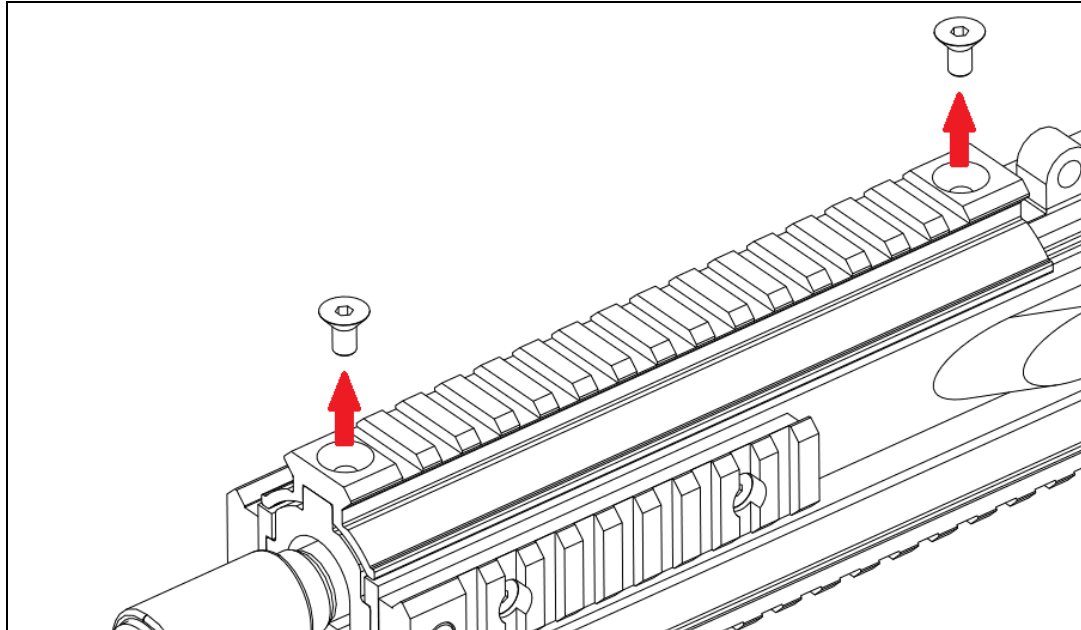

Remove bottom rail screws.

3. Loosen the front screw securing the side-mounted accessory rail. Note that the torx-head screws are retained inside of the accessory rail and will not come free from the weapon. Also note that the screw is detented, a 'clicking' noise is normal when turning.

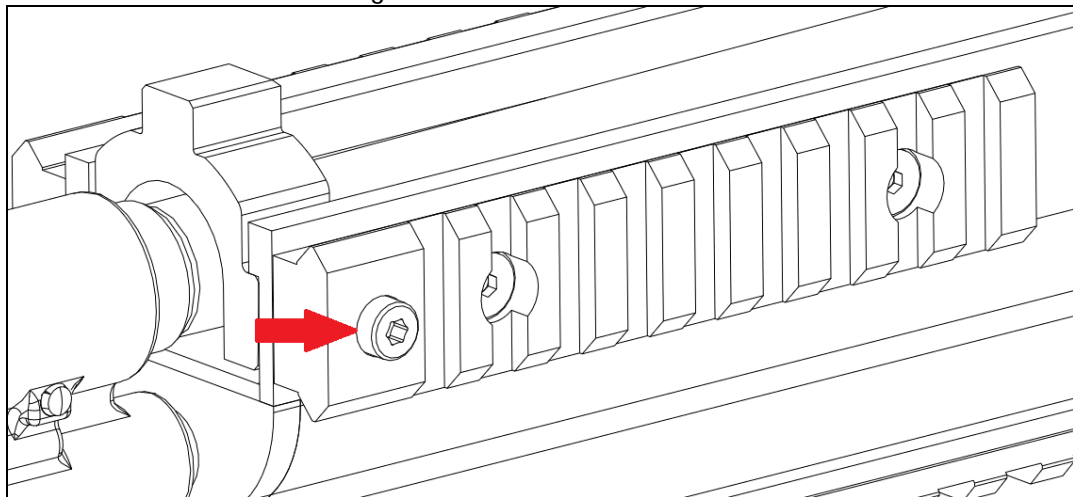

Loosen Torx-head screw.

4. Next loosen and remove the pair of screws which secure the side-mounted accessory rails to the upper receiver. Note that these screws secure into threaded tabs inside the receiver which may fall free once the screws are

removed. Heat may need to be applied to these fasteners as well. Take care when applying heat, as the side-mounted accessory rails are polymer.

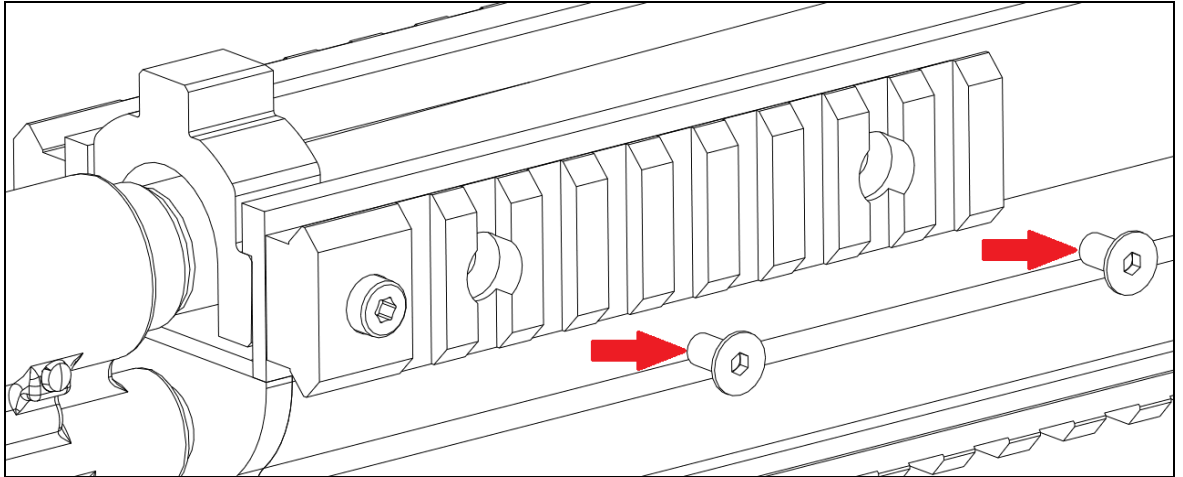

Remove pair of side-rail mounting screws.

5. Locate and position the side-plate on the rifle as shown.

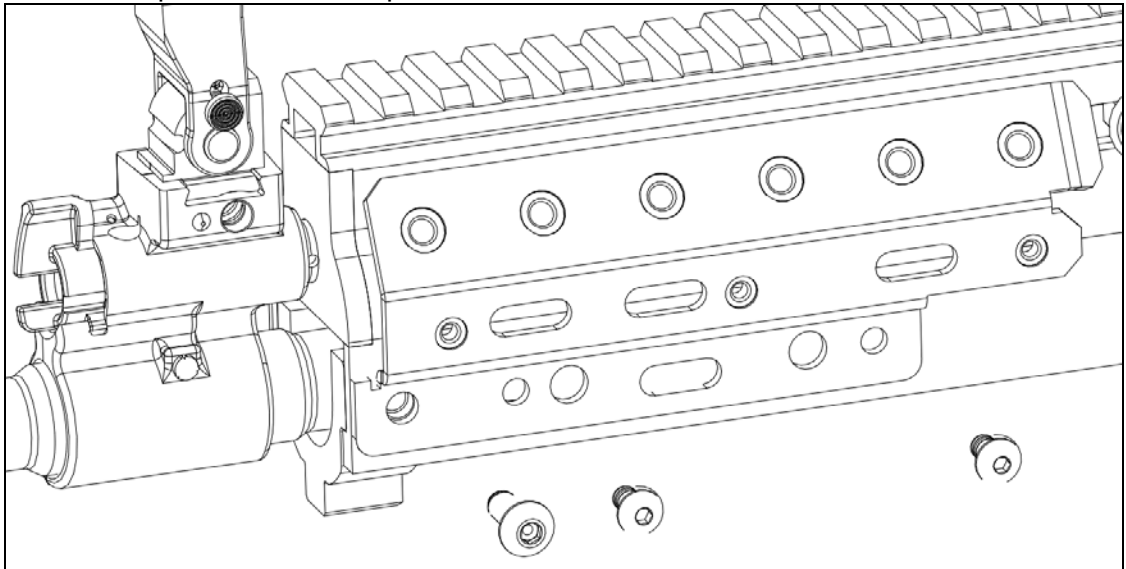

Position the side-plate. Secure using provided hardware.

6. Secure using the provided screws (per side: 1X 10-32 BHCS, 2X M4 BHCS). Note that alignment may need to be adjusted depending on the fit to a particular rifle. It is recommended that the screws be left slightly loose at this stage, and tightened later once alignment is established.
7. Repeat Steps 5 and 6 for the second side-plate.
8. The Handguard can now be installed. Locate and position the handguard on the rifle as shown and secure using the provided hardware.

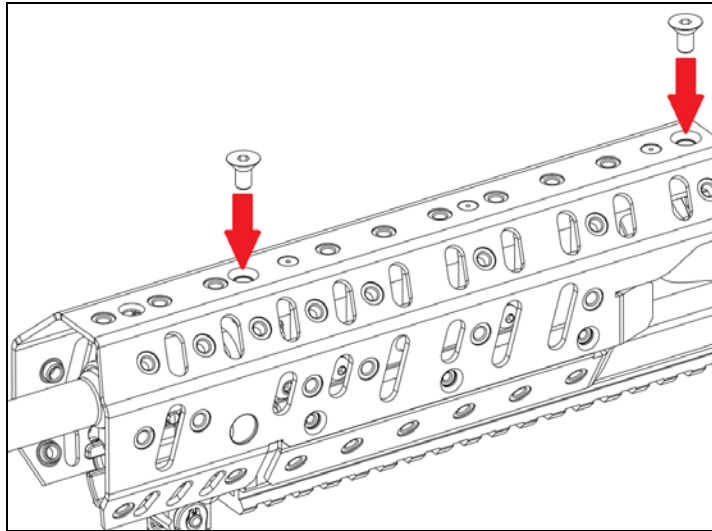

Position handguard over bottom of rifle, secure using hardware provided.

9. Alternate tightening the front and rear screws 1/4-1/2 turn at a time until fully secured. Note that some misalignment may be present until fully tightened.
10. Check the alignment to the side plates. If the holes are out of vertical alignment, the bottom screws may not be fully tightened yet.
11. Check the alignment of the side plates to the handguard at this point. Note that the screw holes may be slightly out of alignment. This is normal, and they will self-align as the remaining fasteners are installed.
12. Begin with the center screw on either side of the handguard. Install both screws loose, then tighten until the head of the screw is flush with the handguard. Alternate sides while tightening to ensure proper alignment.

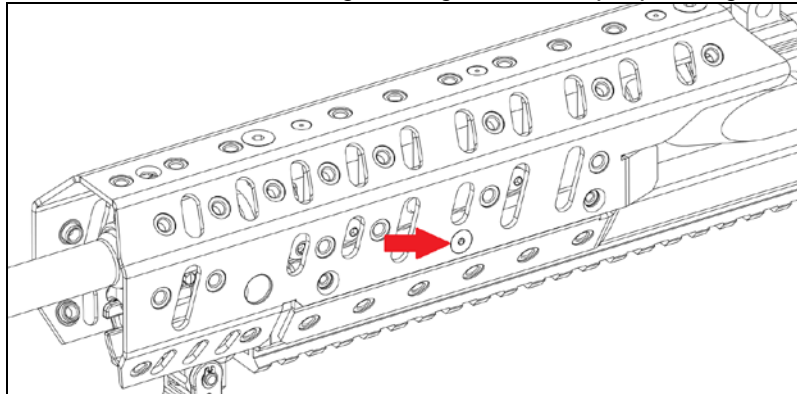

Install the center screw into either side plate.

13. Install the remaining four screws, loose at first and then tighten while alternating to each side (left-to-right) to ensure the handguard centers properly.
14. Note that some receivers may make contact with the six screws which secure the handguard. Witness marks may be left on the side of the receiver as a result.

15. If alignment is acceptable, the handguard can be removed and the side-plate screws tightened fully. Thread-locker may be used to ensure the fasteners remain tight.

Accessory Rails. The five rails, which come standard with each kit, can be assembled wherever a mounting hole (locking press nut) is located. One can place the rail(s) on the 3, 6, and 9 o'clock positions, including the two lower 45-degree positions. Evenly tighten the rail mounting screws, making sure not to over-tighten them as damage to the screws, rail or handguard may occur.

We hope you appreciate the function and quality the CASV SCAR has to offer. If there are any concerns or helpful hints that you can offer to make the CASV SCAR handguard or this instruction manual better, please, do not hesitate to let us know. Your comments and suggestions are always greatly appreciated.

If you encounter any difficulties operating the CASV system, or if your qualified gunsmith/technician has questions regarding installation of the CASV system, feel free to contact the Vltor Service Department, either by telephone: (520) 408-1944 or by email: service@vltor.com

Go To WWW.VLTOR.COM For The Following:

- Operation and Installation Manual, illustrated and up-to-date.
- New Products and Accessories.
- Frequently Asked Questions (FAQ).
- VLTOR News and Related Links.

VLTOR WEAPON SYSTEMS
3735 North Romero Road
Tucson, Arizona 85705 USA

VWS-M019 RevA (30APR2012)